

WILLEM J.M. LEVELT

Talking about space is often notoriously difficult. Take, for instance, giving a route direction. Mary asks a bypasser, Peter, to tell her how to get to the Central Station. If Peter wants to be helpful, and the Central Station is not in view, he will have to retrieve his "cognitive map" of the relevant part of town, locate the present position and the destination, trace the shortest or easiest route between them, find relevant landmarks such as churches, towers, shops along the route, retrieve names or descriptions for these landmarks, and for the directions from one landmark to the next, such as "straight on", "to the left", etc., express these in the right order, check with Mary whether she understands it all, etc. (cf. Klein, 1982 for a detailed theoretical and empirical analysis of route direction tasks). It is common knowledge that the success rate of route directions is not very high. Mary will probably have to repeat her request once or twice before she finally reaches the station.

Or consider describing one's apartment. Even a careful apartment description is a poor substitute for perceiving the apartment, and a speaker knows this intuitively. The description task is so difficult because it requires the speaker to select for expression a very small subset from a sheer infinitude of information he has available about his apartment. Another major problem in this task is how to order what has been selected for expression: where to start with the description (at the front door?), what to mention next (the hallway?, a major room?). Most people develop some sort of touring strategy, deciding on the order of mention by spatial connectivity as if they are walking around through the apartment (Linde and Labov, 1975). This "linearization problem" in talking about space has been further analyzed in experimental studies by Levelt (1981, 1982a) and by Ehrich and Koster (1983).

One could argue that the difficulty in these two examples is primarily one of memory. Both the route and the apartment descriptions involve retrieving and manipulating mental representations; they don't demonstrate that there is any principled difficulty in mapping space on language. But talking about space can still be highly problematic in the absence of any strain on memory, namely, in the case where the spatial relations are perceptually given. Most people are aware of occasional trouble in the use of "left" and "right" which can even arise when the scene is in full view. Less well known is the potential trouble in referring to the other two spatial dimensions, "in front of"/"behind" and "above"/"below". This article will analyze some of the sources of trouble which may arise when these terms are used for referring to perceptual scenes, and in doing so shed some light on the ways in which perceptual relations restrict or limit the uses of language.

The theoretical purpose is, more in particular, to compare two systems of spatial reference, the so-called deictic and intrinsic ways of referring, and to specify how these systems differ from the formal and the perceptual points of view. This will initially be done by a detailed analysis of the first major dimension of spatial reference, denoted by "left" versus "right". We will then move to the second major dimension, and investigate the uses of "in front of"/"behind". It will provide us with a hitherto unknown perceptual restriction on the intrinsic system, which will be called "the principle of canonical orientation". This principle will turn out to play a major role in the analysis of the last and most basic dimension, indicated by the terms "above" and "below". There is, of course, much more to say about the semantics and pragmatics of spatial relation terms. The reader is referred to Miller and Johnson-Laird (1976) for a more comprehensive analysis.

Perceptual limitations on talking about space

1. "LEFT" AND "RIGHT", DEICTIC AND INTRINSIC USE

It is easy to create confusion with "left" and "right". Consider first Figure 1a. With the present text in normal reading position, there can be no doubt that the ball labelled "A" is to the left of the ball labelled "B", and that B is to the right of A.

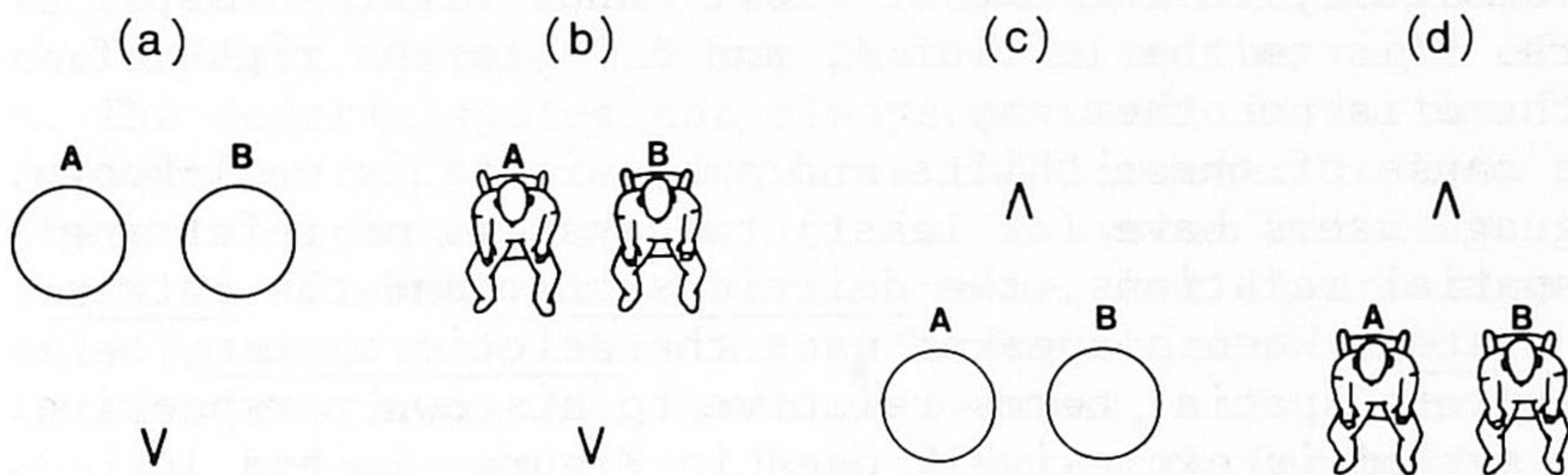

Figure 1. Deictic and intrinsic uses of "left" and "right".

It is a bit more precise to say that the above holds for a viewer positioned at V in the figure, having A and B in full frontal view. In the following, V will be used as a symbol for the directed eye(s) of the viewer. We will further use the following terminological convention: in the cases to be analyzed there is always a "located object" and a "referent object". In the expression "A is to the left of B", for instance, A is the located object, and B is the referent object. In "B is to the right of A", B is the located object, and A the referent object. The roles of the objects involved will mostly be clear from the context, but the explicit terminology will here and there be needed.

Turning now to Figure 1b, one can observe the first trouble with "left" and "right". As in Figure 1a the viewer is justified in saying that B is to the right of A, but it would not be false to say that B is to A's left, since B sits at A's left hand. So, B is both to the right and to the left of A. Are these uses dependent

on the position of the viewer? To test this, consider Figure 1c. The viewer of Figure 1a has walked around balls A and B and watches them from behind, so to speak. From this perspective, B is unambiguously to the left of A, and A is to the right of B. In other words, the relations are the reverse of those in Figure 1a; changing the viewer's perspective does affect the use of "left" and "right". When the viewer of Figure 1b walks around A and B to end up in the position depicted in Figure 1d, the ambiguity in the use of "left" and "right" disappears. B is to the left of A, and A is to the right of B, there is no other way.

The cause of these shifts and ambiguities is well-known. Language users have (at least) two systems of referring to spatial relations, the deictic system and the intrinsic system. When a speaker uses the deictic system, he interprets spatial terms relative to his own perspective. This system is exclusively used in Figures 1a and 1c. Changing the speaker's perspective changes the choice of "left" and "right" accordingly. Notice that a listener who heard the speaker's spatial description would not be able to interpret it correctly without knowing the speaker's position vis-à-vis the scene. The deictic system may have been designed for communication situations where the interlocutors are aware of one another's perspective. Throughout this paper, however, we will assume that the viewer/speaker more or less coincides with the listener in terms of location and orientation. It may well be the case that the uses of spatial terms vary with the spatial relations between speaker and listener, given the scene. This will, however, not be explored here.

Turning now to Figures 1b and 1d, one should, firstly, observe that the viewer could also use the deictic system. He will then come up with the same terms as the viewer in Figures 1a and 1c, respectively. But there is another possibility in Figures 1b and 1d, namely to use the intrinsic system. In this system of reference spatial terms are interpreted relative to the intrinsic orientation of the referent objects themselves. In Figures 1b and 1d person A is oriented in such a way

Perceptual limitations on talking about space

that B is at his left hand. This state of affairs is independent of the viewer's perspective; it holds in 1b as well as in 1d. In order to use the intrinsic system the language user must be able to interpret the scene. It must be clear what sorts of objects the scene contains. If the viewer in Figure 1b lost his glasses a moment before the experiment, he might not be able to see that A and B are sitting persons. If he perceives A as a bag of potatoes, he could not felicitously say that B is to the left of A. His only recourse would be to use the deictic system, and say that B is to the right of A. The deictic system can always be used; it is the default system, but it requires the listener to know where the speaker is. The intrinsic system not only requires interpretation of the scene, but it can also only be used when there are referent objects with an intrinsic orientation, such as persons, cars, churches, chairs, telephones, etc. It will not work for balls, round or square tables, trees, heaps of sand, etc. (at least not for "left", "right", "in front of", or "behind"). This is why objects A and B were drawn as circles in Figures 1a and 1c; they do not allow for intrinsic interpretation.

The ambiguity observed in Figure 1b is now explainable. The deictic system and the intrinsic system are in full opposition. The conflict disappears, however, when the viewer moves to the position depicted in Figure 1d. There, B is to the left of A both from the viewer's perspective (the deictic system) and given A's orientation (the intrinsic system).

This duplicity of systems for spatial reference is quite general for the languages of the world, though there are many differences of detail (see, for instance, Weissenborn and Klein, 1982). This gives rise to several important questions. The hardest one is why linguistic evolution has provided us with this duplicity. Do the two systems serve different functions? Also do the two systems derive from a common source which is phylogenetically or ontogenetically prior to their separate developments? A second issue is how language users deal with potential confusion between the systems. How can a

hearer know which system a speaker is using? Are there any perceptual or linguistic cues which reveal to the listener which system is in operation? A third set of problems concerns the internal structure of the systems. Have they any marked mathematical and perceptual properties? Does the same duplicity hold for the "in front of"/"behind" dimension and for "above"/"below", and, if so, how are these three related? The present paper will mainly address this third set of issues by giving a phenomenological account of the systems' properties. Still, in a concluding section some attention will be given to the first two issues.

2. CONVERSENESS AND TRANSITIVITY IN DEICTIC VERSUS INTRINSIC USE OF "LEFT" AND "RIGHT"

Are "left" and "right" converse relations, i.e., is it the case that if A is to the left of B, B is to the right of A? Notice that the property of converseness can be crucial for the interpretation of spatial descriptions. Peter leaves the office to pick somebody up at the station, but his car refuses to start. Peter returns from the parking place to the office building and asks Mary whether he can use her car. Mary gives him her key, and knowing that Peter is probably unfamiliar with her car, adds "you parked your car just to the right of mine". Peter is likely to conclude that Mary's car is to the left of his, but this conclusion is only correct if converseness holds. It doesn't, as we will see, and Peter might have to return for further help.

Converseness holds only for the deictic system. The viewer's perspective in Figure 1a, repeated as Figure 2a, guarantees that B is to the right of A, and that A is to the left of B. There is no possibility that the one relation holds without the other holding as well.

But compare this to the situation in Figure 2b. An intrinsic interpretation is possible here (and in order to indicate that this is the intended interpretation we left out the viewer, whose position is irrelevant in the

Perceptual limitations on talking about space

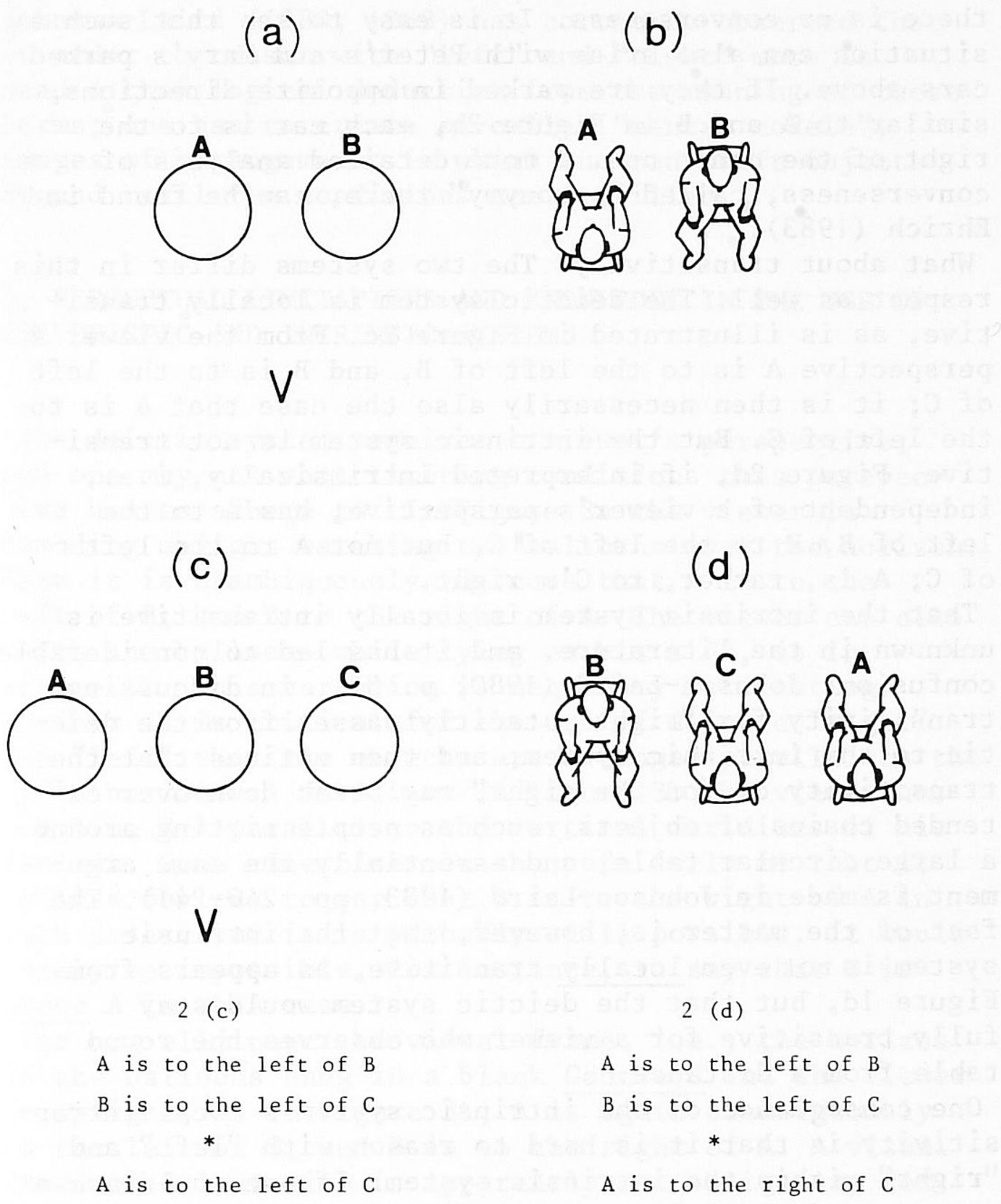

Figure 2. Converseness and transitivity for deictic and intrinsic "left" and "right".

intrinsic system). B is to the right of A in this figure, but A is not to the left of B. In fact, A is to the right of B. So, A and B are to the right of one another;

there is no converseness. It is easy to see that such a situation can also arise with Peter's and Mary's parked cars above. If they are parked in opposite directions, similar to A and B in Figure 2b, each car is to the right of the other one. A more detailed analysis of converseness, called "antonymy" there, can be found in Ehrich (1983).

What about transitivity? The two systems differ in this respect as well. The deictic system is locally transitive, as is illustrated in Figure 2c. From the viewer's perspective A is to the left of B, and B is to the left of C; it is then necessarily also the case that A is to the left of C. But the intrinsic system is not transitive. Figure 2d, if interpreted intrinsically, i.e., independent of a viewer's perspective, has A to the left of B, B to the left of C, but not A to the left of C; A is, rather, to C's right.

That the intrinsic system is locally intransitive is unknown in the literature, and it has led to considerable confusion. Johnson-Laird (1980, p. 87), in discussing transitivity for "right", tacitly passes from the deictic to the intrinsic system, and then notices that the transitivity of "on the right" may break down over extended chains of objects, such as people sitting around a large circular table, and essentially the same argument is made in Johnson-Laird (1983, pp. 240-241). The fact of the matter is, however, that the intrinsic system is not even locally transitive, as appears from Figure 1d, but that the deictic system would stay fully transitive for a viewer who observes the round table from a distance.

One consequence of the intrinsic system's local intransitivity is that it is hard to reason with "left" and "right" within the intrinsic system. If one would ask a person to draw the correct spatial arrangement from the description "John is to the left of Mary, Mary is to the left of Peter, and John is to the right of Peter", i.e., the arrangement depicted in Figure 1d, it will take a long time to find the correct solution (one is likely to come up with the quasi-solution of arranging the three persons evenly around a circular table).

Perceptual limitations on talking about space

Johnson-Laird (1980, 1983) has correctly observed that in order to reason with "left" and "right" more is needed than logical deduction from the meaning of these terms; one has to create so-called "mental models", images of arrangements in which one can shift objects around until the conditions are fulfilled.

3. PERCEPTUAL LIMITATIONS AND KNOWLEDGE IN THE USE OF THE DEICTIC AND INTRINSIC SYSTEMS

The deictic system requires a viewer's perspective, and one may ask what limiting conditions this perspective has to adhere to. In Figure 3a the viewer is standing upright watching two balloons over the horizon. Here it is unambiguously the case that A is to the left of B, and B to the right of A. The viewer can also watch the balloons while lying on his side, as in Figure 3b. This variation is necessary for testing whether it is critical for the use of deictic "right" and "left" that the objects are arranged parallel to the eye's horizontal meridian. In Figure 3b the viewer has the line B-A parallel to the vertical meridians of his retinas. Some exercise on the sofa tells me that it is less obvious to say that B is to the right of A in such cases, but it is probably still possible. It would surely be impossible, for instance, to say that B is above A in this case.

But now eliminate the visual frame, i.e., the horizon. If the balloons hang in a blank Ganzfeld and the viewer is upright, as in Figure 3c, A is again unambiguously to the left of B, and B is to the right of A. A visual frame of orientation is apparently not obligatory for the deictic assignment of "right" and "left". But the viewer still has two other cues here. The objects are arranged parallel to the retinas' horizontal meridian, and the vestibular system tells the viewer that this arrangement is orthogonal to gravity. Let us remove the first cue and put the viewer on his side, as in Figure 3d. Is A still to the left of B in this case?

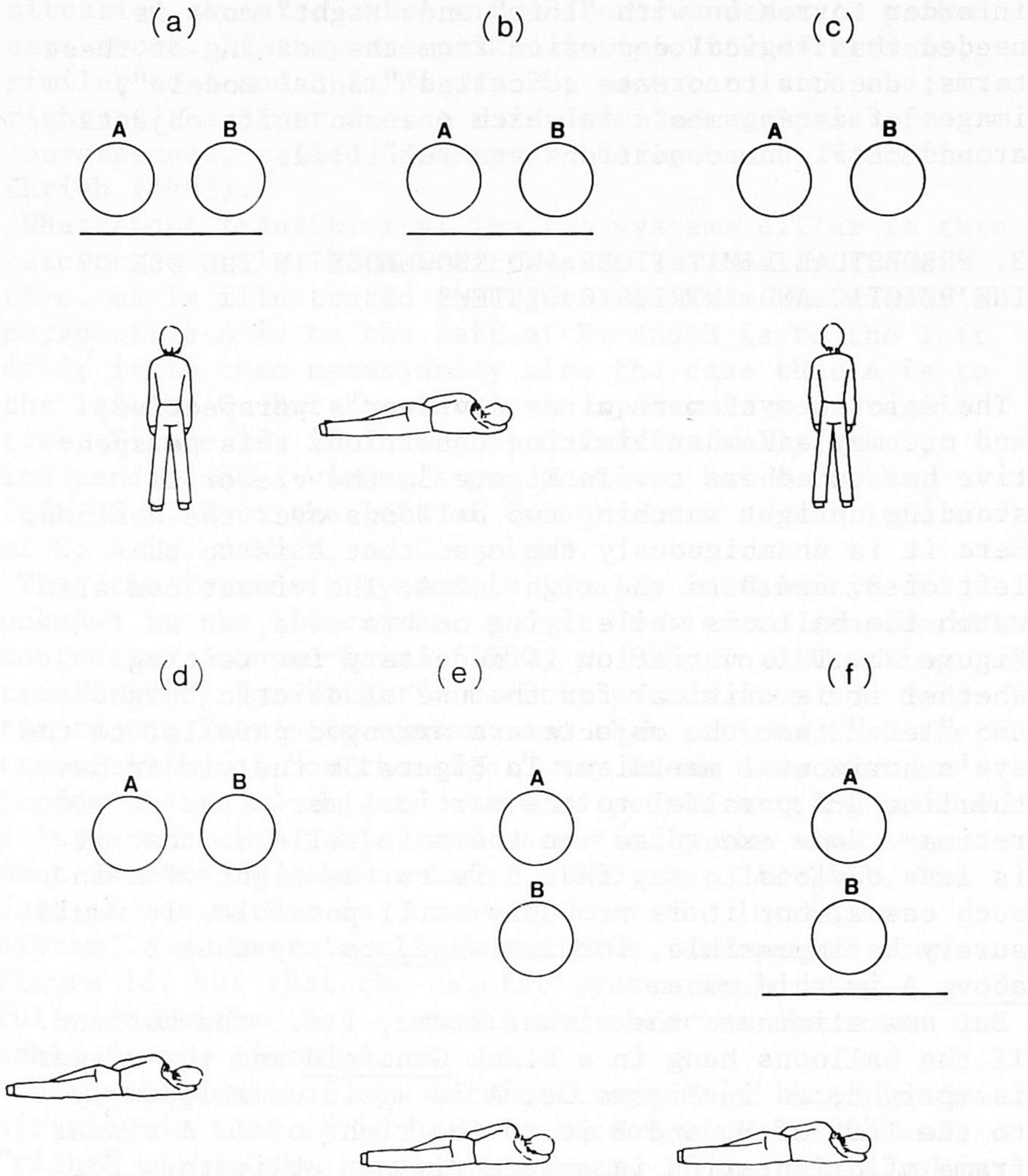

Figure 3. Perceptual cues for deictic use of "left" and "right".

Intuitions waver, but some more looking at a white wall from the sofa convinced me that it is a bit odd to say that A is to the left of B, whereas it is probably

Perceptual limitations on talking about space

possible to say that A is below B.

In order to test which cue is the more important one, gravity (which tells the viewer about the "objective" horizontal arrangement) or retinal arrangement, one must test the case depicted in Figure 3e, and compare it to 3d. In 3e the vestibular information tells the viewer that the balloons are not arranged in a horizontal plane, though they are still aligned parallel to the retinas' horizontal meridian. I feel one could say "B is to the right of A" in this case which would indicate dominance of the retinal over the vestibular information. But if the vestibular information is further assisted by an orienting visual frame, such as the horizon in Figure 3f, it is very odd to say that B is to the right of A. Balloon B is below A in this case.

Table 1 summarizes the observations made so far. It lists for each of the situations in Figure 3 whether or not one can say "B is to the right of A" (plus a "?" for the two somewhat doubtful cases); it also marks for each case whether the line A-B is in a horizontal plane given (a) vestibular information, (b) visual frame information, and (c) retinal information, i.e., parallelism to the retinas' horizontal meridian.

TABLE 1. The appropriateness of saying "B is to the right of A" for different combinations of perceptual cues.

"B is to the right of A"	Figure	Perceptual Cue		
		Vestibular	Visual Frame	Retinal Orient
Appropriate	Fig.3a	+	+	+
	Fig.3b	+	+	-
	Fig.3c	+	0	+
?	Fig.3e	-	0	+
Inappropriate				
?	Fig.3d	+	0	-
	Fig.3f	-	-	+

It is clear from this table that not all possible cases have been studied. The vestibular and visual frame cues are essentially three-valued: they can be of the type "A-B is horizontally aligned", "A-B is vertically aligned", or the cue can be missing (for the vestibular system the latter can only be arranged in a space craft

or in free fall). The retinal information is two-valued, horizontal or vertical. Boolean combination gives, therefore, 18 possible relations between cues. Figure 3 and Table 1 present only 6 of them. The study of most other cases requires more complex arrangements than the private facilities used so far; the space craft mentioned and a tiltable room would be helpful.

For the present our conclusions must be based on the information in Table 1, and the simplest summary of these results is that in the deictic system one can confidently express a spatial relation as "right" or "left" if there is agreement in a horizontal direction between at least two of the three cues. If two of the three cues conspire in the vertical direction, as in 3f, one can equally confidently use "above" or "below". The table strongly suggests that none of the cues is a necessary condition for deictic use of "left" and "right". Or, more precisely, none of the cues necessarily has to be positive; the other ones can always compensate. The table leaves some doubt in this respect for the vestibular case, since the one negative case (e) is doubtful and the other one (f) does not allow for "left" and "right". But a Gedanken-experiment can help here. If one would arrange two balls, A and B, on one's desk in such a way that B is to the right of A from one's own perspective, then it would probably not matter much if the whole room would be orbiting the earth: B will still be perceived as being to the right of A. Another, but related question is whether a single cue's negative information can disrupt the system. Table 1 only answers this for the retinal cue; if A-B is arranged vertically over the retina, as in 3b, the other two cues can overrule this. But it would be premature to answer the question for negative vestibular or visual frame information.

Let us now turn to some conditions which have to be met for the intrinsic system to operate. As was discussed earlier, the use of the intrinsic system requires interpretation of the scene, and in particular of the identity of the objects involved. In order to say that B is to the right of A, one must recognize

Perceptual limitations on talking about space

that the referent object A has an intrinsic right side. But this is not a perceptual fact per se. Consider, for instance, some objects which we take to have a right and a left side: people, different types of animals, cars, churches, chairs, desks, etc. These objects do not share any perceptual properties. There is only a loose functional relationship between them which we recognize through extensive experience. The left/right structure of people and (most) animals is probably an interpretation-by-analogy to our own left/right structure; the main sense organs are up/front, and that is how the organism is oriented in its world. From this we can derive what is left and right. Cars, churches, chairs, desks derive their left/right organization from the ways human beings are typically oriented towards them when they are used. This can lead to interesting complications. Figure 4 represents a desk and a chair, and for each of them it is indicated what is intrinsic left, front, and right.

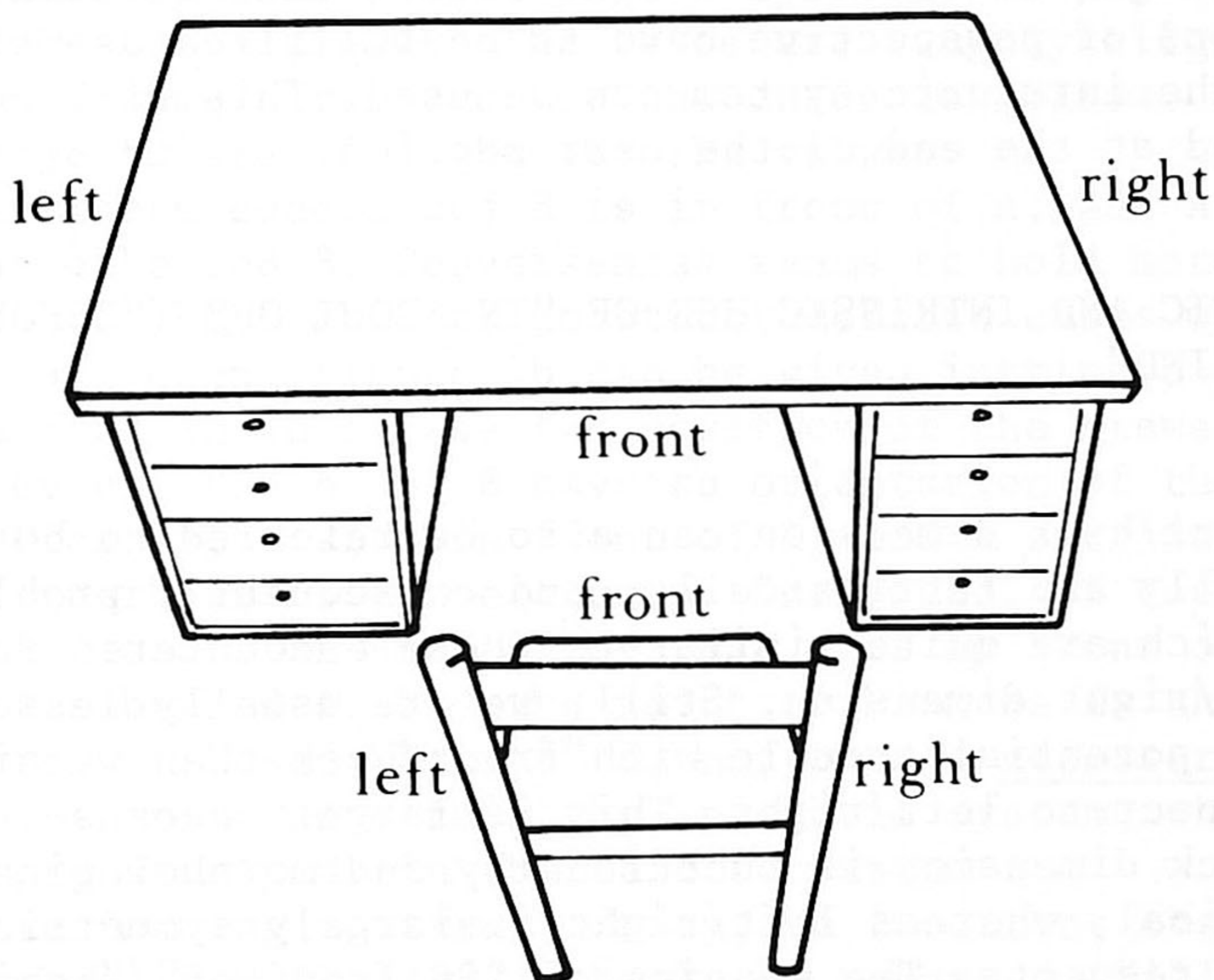

Figure 4. Different arrangements of intrinsic "left", "front", and "right" for a chair and a desk.

It should be noticed that for the chair, left, front, and right are related in the same way as for people. For the desk, however, left and right are reversed with respect to what is front. This can only be understood if one takes into account what is the canonical position of a person using chair and desk. For both objects, "right" is what is right for that person, and "left" is what is left for that person. For the chair, "front" is where that person is facing, but for the desk, "front" is the side facing the person. We will return to this latter fact in the next section. For a full treatment of these aspects of the intrinsic system, see Miller and Johnson-Laird (1976).

The use of the intrinsic system is independent of the speaker's position with respect to the scene. So far we have observed that the intrinsic system is independent of the speaker's perspective; it is in the first place knowledge-based, whereas the deictic system is perception-based. We will shortly have to add a slight but interesting qualification to the effect that certain conditions of perspective have to be fulfilled as well before the intrinsic system can be used. This will be discussed at the end of the next section.

4. DEICTIC AND INTRINSIC USE OF "IN FRONT OF" ("BEFORE") AND "BEHIND"

The front/back dimension can also be referred to both deictically and intrinsically, and consequently problems arise which are quite similar to those encountered for the left/right dimension. Still, we are usually less aware of potential trouble with front/back than we are with respect to left/right. This is largely because the front/back dimension is functionally and morphologically asymmetrical, whereas left/right is largely symmetrical in these respects. The meaning of "in front of"/"behind" is related to the biologically highly important distinction between "closer to me" and "further from me", and to the distinction between the front side and the

Perceptual limitations on talking about space

back side of the body (see Clark, 1973 for a thorough analysis of these issues). Nothing of equal functional and morphological importance goes with the distinction between left and right. It is very hard to become aware of the existing asymmetries of the human body since they are mostly internal and irrelevant for information exchange with the environment. Only a sufficient degree of right- or left-handedness provides a person with some degree of functional information about what is left and what is right, or as Corballis and Beale (1976) put it: "It is probably his handedness which first informs the child about the difference between left and right" (p. 175). This small privilege would thus be denied to ambidexters, and the reader is referred to Corballis and Beale (*op. cit.*) for a review of the evidence which relates left-right confusion to lack of dominance or lateralization.

Let us first consider the properties of converseness and transitivity for "in front of" ("before") and "behind". Figure 5a is a bird's-eye view of two static balloons and a viewer. The three are roughly aligned. Let us assume here, and for the cases to follow, that all objects are in sight for the viewer.

Under these conditions B is in front of A, and A is situated behind B. Converseness seems to hold here, and I have not been able to construct deictic cases where it breaks down. Figure 5b can be given intrinsic interpretation. In that case the position of the viewer is irrelevant, and A and B have an orientation of their own. Clearly, B sits in front of A, and A sits in front of B; there is no converseness. One could, of course, orient A and B in such a way that A is in front of B and B is behind A, but the point to be made is that "in front of" and "behind" do not bear a necessarily converse relation within the intrinsic system, whereas they presumably do in the deictic system.

Before turning to transitivity, an important observation made by Hill (1982) should be reported. Hill noticed that not all languages use the equivalents of "in front of" and "behind" in the way discussed for Figure 5a. The Afro-Asiatic language Hausa, for instance,

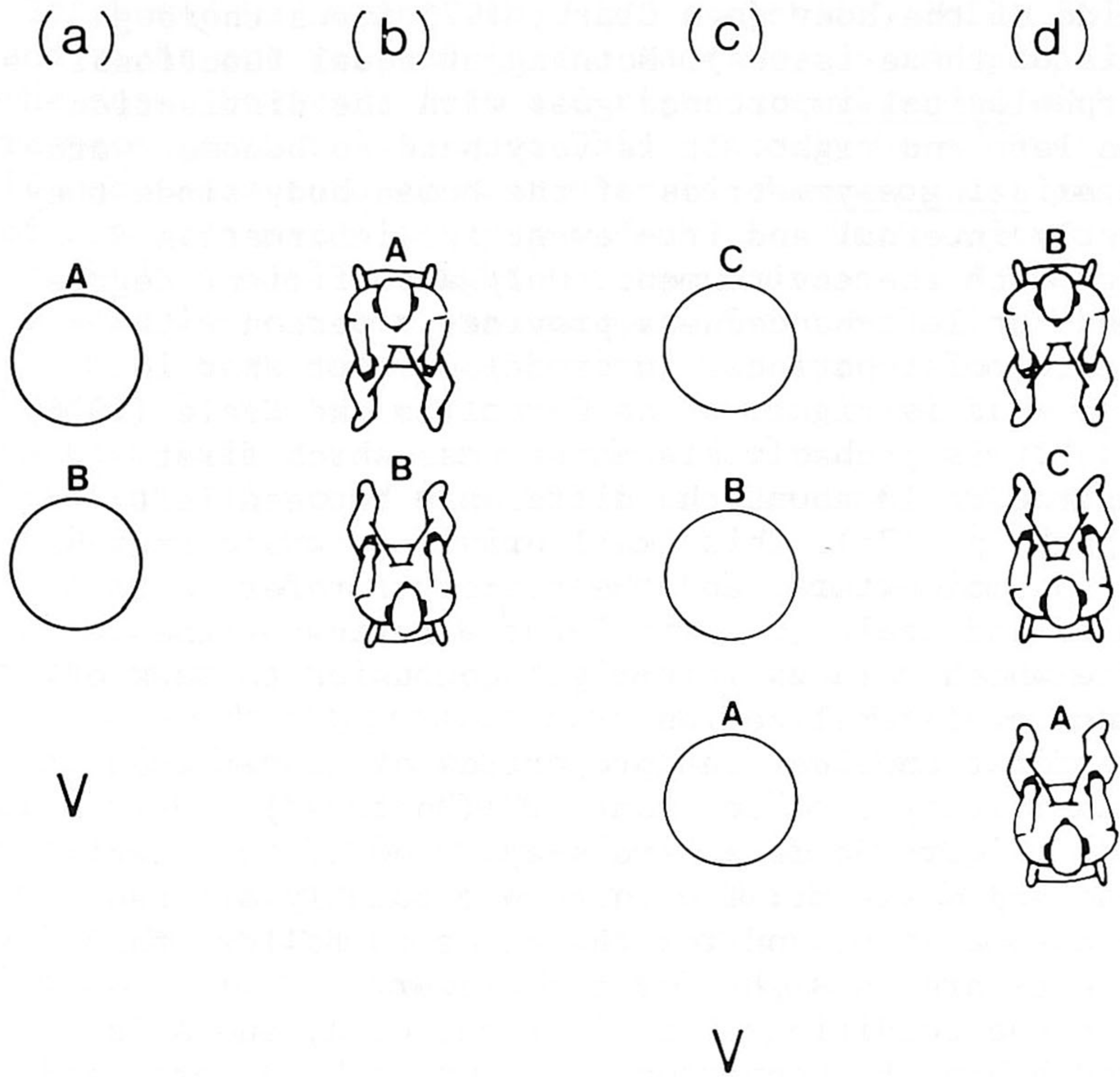

5 (c)

5 (d)

A is in front of B

A is in front of B

B is in front of C

B is in front of C

*

*

A is in front of C

A is behind C

Figure 5. Converseness and transitivity for deictic and intrinsic "in front of" and "behind".

requires the viewer in that situation to say that A is in front of B, at least if A is clearly visible. Hill calls Hausa an "aligning" language. It is as if B is "oriented" towards A in just the same way as the viewer is oriented towards A; A is in front of B just

Perceptual limitations on talking about space

as it is in front of the viewer. English, Dutch, and many other languages are different, they are "facing" languages. It is as if B is facing the viewer, so that A is behind B. Still, it is probably the case that within an aligning language the converseness property holds for the deictic system, as it does for a "facing" language.

The deictic system is also transitive for "before" and "behind". This is depicted in Figure 5c. A is in front of B, B is in front of C, and A is in front of C. I found no way to violate this for the deictic system. It is easy, however, to violate transitivity for the intrinsic system. This is done in Figure 5d, which is constructed in analogy to Figure 2d. A is in front of B, B is in front of C, but A is behind C. The lack of converseness and transitivity for "before"/"behind" in the intrinsic system may complicate reasoning with these terms in the same way as was observed above for reasoning with intrinsic "left" and "right".

Turning now to a discussion of some perceptual conditions on the deictic use of "before" and "behind", we must first correct some noticeable confusion in the literature. Earlier we described the objects A and B in Figure 5a as static objects. Hill (1982) observed that the deictic use of "before" ("in front of") and "behind" depends on whether A and B are static or dynamic. His argument is illustrated in Figure 6.

Figure 6a is a copy of Figure 5a, it shows the viewer and the static objects A and B. Remember that B is in front of A for the viewer. Figure 6b is the same, except for the arrows which indicate that A and B are moving away from the viewer. Hill observed that in this case A is in front of B, and B is behind A. Though the observation is entirely correct, the interpretation is not.

Consider, first, Figure 6c which is the same again, except for the reversal of the directions of motion. Now, the situation is the same again as in Figure 6a: B is in front of A, and A is behind B. So it is not the dynamic character of the scene that dictates the reversal of "in front of" and "behind", as Hill supposes. It

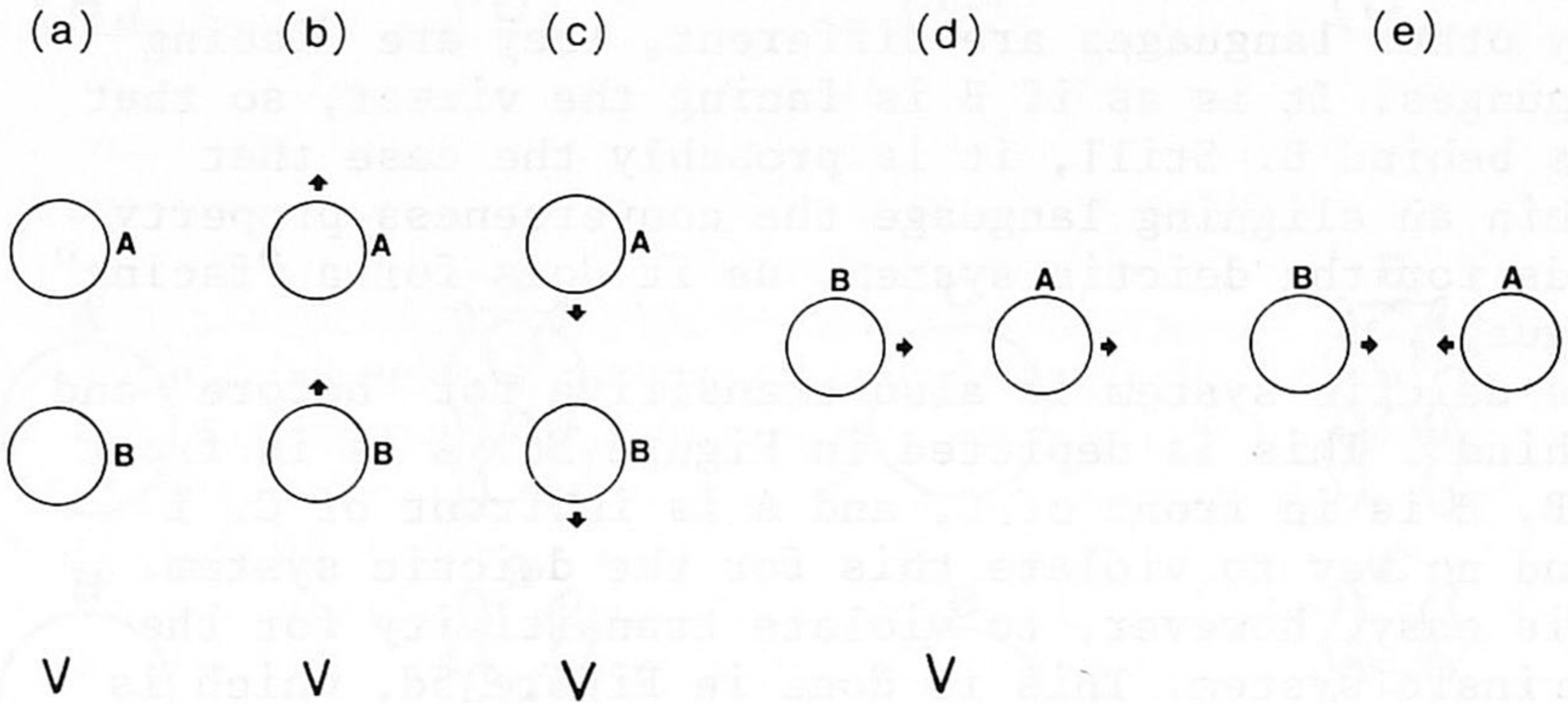

Figure 6. Deictic and intrinsic use of static and dynamic scenes.

depends, rather, on the direction of motion. More important, however, is that the viewer's position is irrelevant. Whether the viewer watches A's and B's moving from a perspective as in Figure 6b, or from one as in 6d, A will always be in front of B, and B will be behind A. But if the use of "in front of" and "behind" are independent of the viewer's position, we are quite probably operating in the intrinsic system, and not in the deictic system as Hill supposes (and Ehrich 1983 with him). Objects without intrinsic fronts acquire a front by moving; the front is the most forward side of the object in motion. This predicts that the deictic property of converseness doesn't necessarily hold for such moving objects. Figure 6e shows that this is correct. Here A is moving towards B, and B is moving in opposite direction towards A. It can doubtless be said in this situation that B is in front of A, and A is in front of B.

The relevance of Hill's observation is that certain stimulus conditions, such as those in Figure 6b, can make it hard to use the deictic system; the language user is almost forced to switch to the intrinsic system. Ehrich (1983) has made a related observation for a situation resembling Figure 5b. It is exceedingly hard

Perceptual limitations on talking about space

to use the deictic system in a case like that one. If the observer would be in the same position with respect to A and B as the viewer in 5a, it would be very hard to say that A is behind B, although that would be correct in the deictic system. In other words, if a referent object has an intrinsic front, either by itself or acquired through movement, there is a very strong tendency to use the intrinsic system for "in front of" and "behind". This clearly differs from the case of "left" and "right": the situation of Figure 1b allows equally well for deictic and intrinsic use of these terms. Such a balance does not arise in the situation of Figure 5b. I will return to this issue in the final section of this paper.

Returning now to deictic use, and asking ourselves what stimulus conditions have to be fulfilled in order to say that A is in front of B, we arrive at the normal cues for depth perception. Handbooks of visual perception, such as Kaufman (1974), give extensive reviews of these cues which need not be repeated here. The viewer in Figure 6a can derive that B is in front of A by considering occlusion relations between A and B, by using stereopsis or movement parallax, by comparing the visual angles covered by A and B, etc. It is not wholly irrelevant for the use of deictic terminology which cue is the effective one. Hill's (op. cit.) observation that for a speaker of Hausa B is behind A in the situation of Figure 6a only holds if A and B are both clearly visible. If B occludes A, but the speaker knows that A is at the other side of B, then A is said to be "behind" B.

Occlusion also seems to play a special role in the use of "before"/"behind" in English (and, mutatis mutandis, for other languages, such as Dutch and German). However, this has to do with the distinction between horizontal and vertical arrangements. Remember that there were clear conditions on horizontality for the plane A/B/viewer as far as the deictic use of "left" and "right" was concerned. Imagine that A, B, and the viewer in Figure 6a are vertically aligned, with A in the highest position, and the viewer looking upwards

from the lowest position. The observer could then say that A is above B. This will be further discussed in the next section. Here we consider whether the viewer could also say "B is in front of A", or "A is behind B" in this situation. The answer seems to be affirmative just in case B partly or wholly occludes A. One can look up in the air and say "the sun is behind the clouds", or "there are clouds in front of the sun", but this does require the clouds to cover the sun to some degree. It would, in fact, be untruthful to say that the sun is behind the clouds when it is not covered by them. The use of "above" does not have this restriction. One can say that the sun is above the clouds even when there is no occlusion; it simply means that the sun is in a higher position than the clouds (see the next section). If it is correct to say that the deictic use of "before"/"behind" requires a roughly horizontal arrangement of observer and objects, just as the deictic use of "left"/"right", one should consider the possibility that these cases of occlusion involve some form of intrinsic use. It is not impossible that clouds are perceived to have intrinsic fronts (the side turned towards us), or that, more generally, an occluding object which becomes a frame of reference for the occluded object, acquires an intrinsic front, just as a moving object does. This possibility, however, will not be further analyzed here.

Let us now turn to normal intrinsic use of "before"/"behind" and its perceptual limitations. Figure 7a shows a balloon which is "in front of" the chair, given the chair's intrinsic orientation. How resistant is intrinsic use to deictic orientation cues? In 7b the chair has tumbled over, but the balloon has been displaced as well so that the same spatial relation is maintained between chair and balloon as in 7a. It is virtually impossible now to describe the situation by "the balloon is in front of the chair"; it is, rather, "over" or "above" the chair.

How can this be understood? Apparently, intrinsic use of "in front of" depends on the reference object being in its "canonical" or normal position with respect to

Perceptual limitations on talking about space

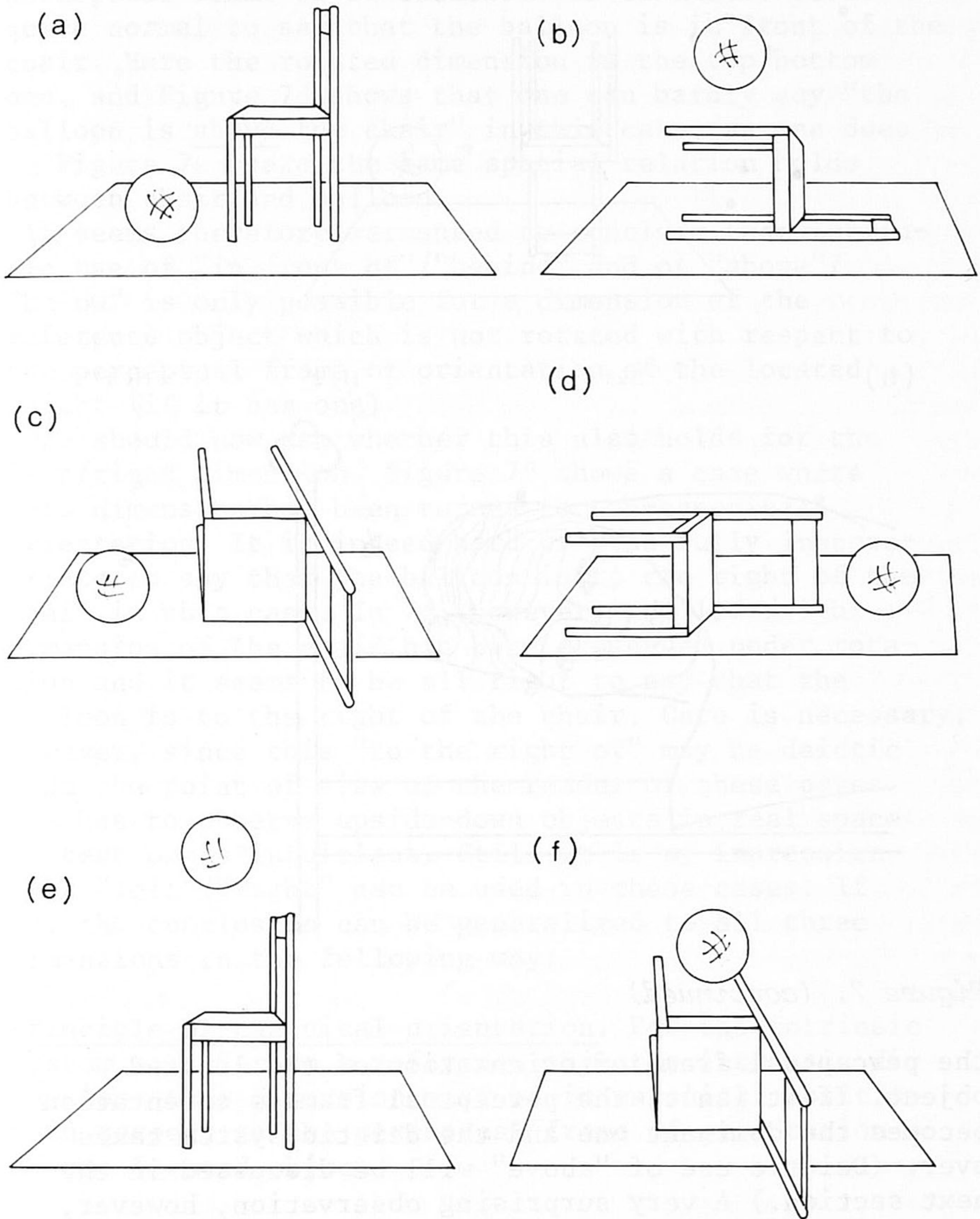
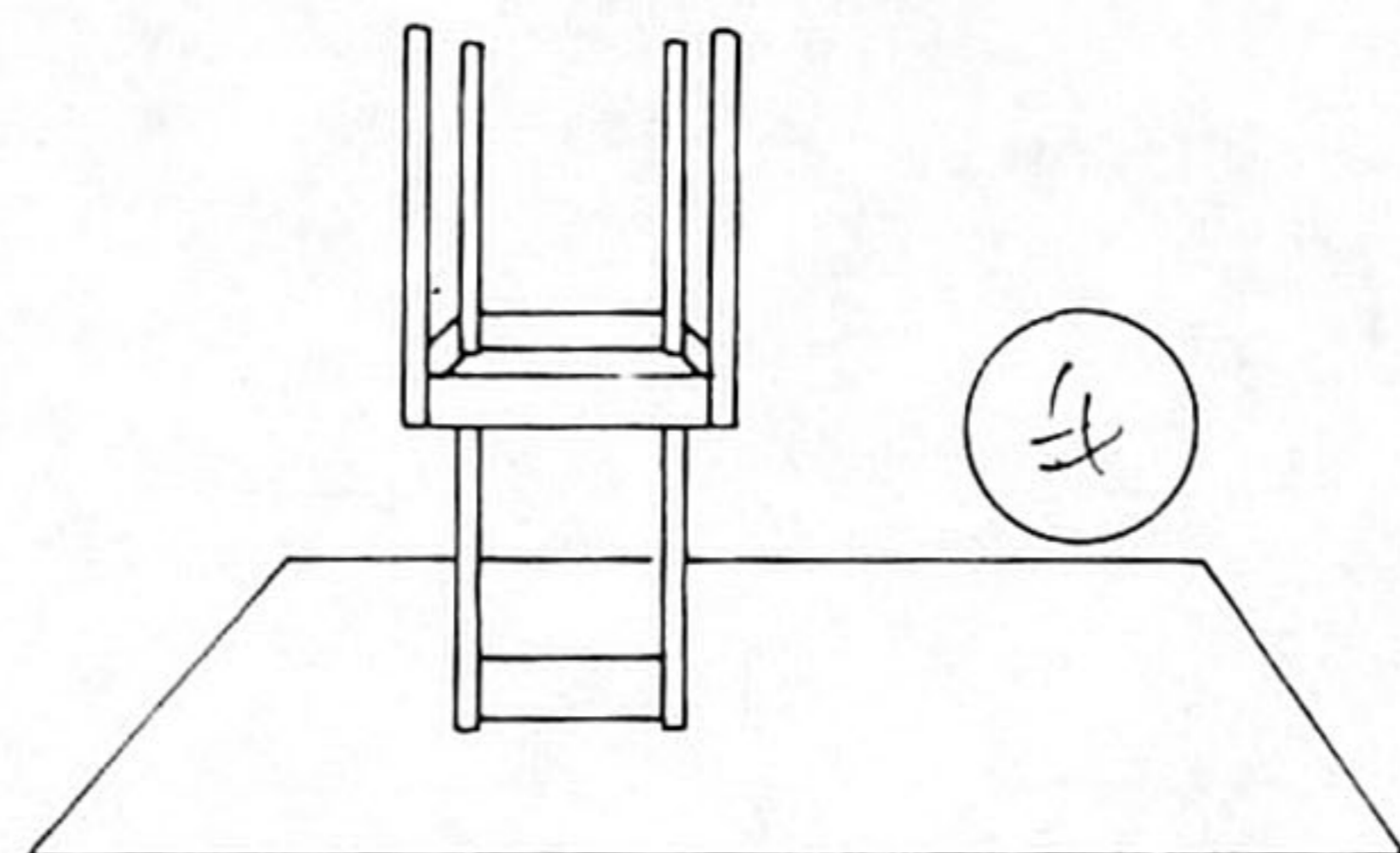

Figure 7. The principle of canonical orientation for intrinsic use.

(g)



(h)

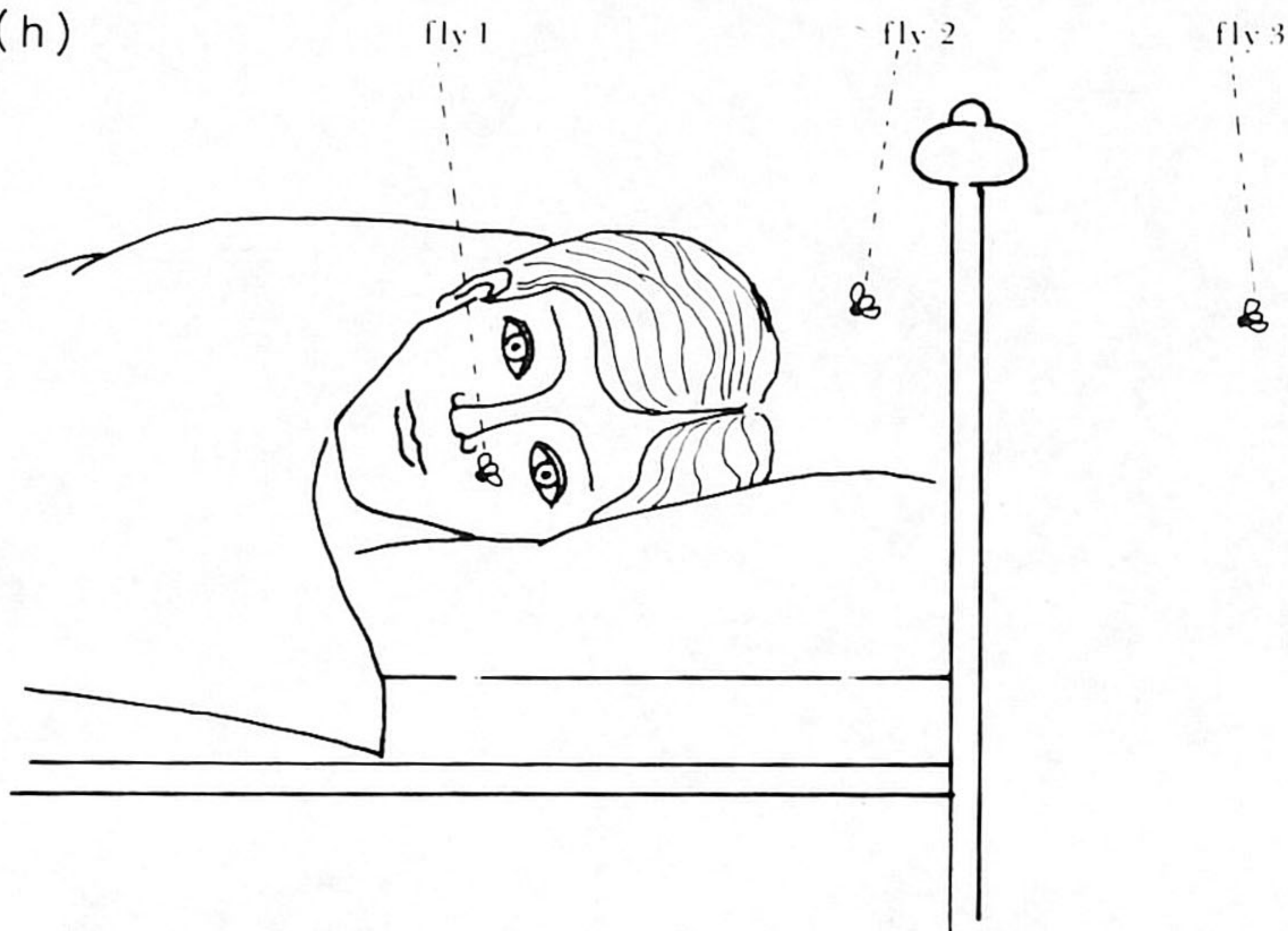

Figure 7. (continued)

the perceptual frame of orientation of the located object. If it isn't, the perceptual frame's orientation becomes the dominant one and the deictic system takes over. (Deictic use of "above" will be discussed in the next section.) A very surprising observation, however, is that intrinsic use is still possible for a dimension that is preserved under rotation of the reference object. An example is given in Figure 7c, where the chair is also in non-canonical position but with the front/back dimension preserved with respect to the

perceptual frame of orientation. In this case it is quite normal to say that the balloon is in front of the chair. Here the rotated dimension is the top/bottom one, and Figure 7d shows that one can hardly say "the balloon is above the chair" in this case, as one does in Figure 7e where the same spatial relation holds between chair and balloon.

It seems therefore warranted to conclude that intrinsic use of "in front of"/"behind" and of "above"/"below" is only possible for a dimension of the reference object which is not rotated with respect to the perceptual frame of orientation of the located object (if it has one).

One should now ask whether this also holds for the left/right dimension. Figure 7f shows a case where this dimension has been turned to non-canonical orientation. It is indeed hard or even fully inappropriate to say that the balloon is to the right of the chair in this case. In 7g, however, the left/right dimension of the chair has been preserved under rotation and it seems to be all right to say that the balloon is to the right of the chair. Care is necessary, however, since this "to the right of" may be deictic from the point of view of the reader of these pages. One has to observe upside-down objects in real space to test one's intuitions. Still it is my impression that "left"/"right" can be used in these cases. If so, the conclusion can be generalized to all three dimensions in the following way:

Principle of canonical orientation. For the intrinsic system to refer to a reference object's intrinsic dimension, that dimension must be in canonical position with respect to the perceptual frame of orientation of the located object.

The perceptual frame of orientation will normally be the experienced vertical, which in its turn derives from visual frame, vestibular or retinal orientation information. This is the case for all discussed examples 7a through 7g. The perceptual frame of the

located object, furthermore, will normally be the perceptual frame of the referent object as well. This also holds for all cases 7a through 7g.

But it is possible to construct exceptions, i.e. cases where the perceptual frame for the located object is not the perceived vertical, and where the frame of the located object differs from the frame of the referent object. Such exceptions are depicted in Figure 7h, which shows John's face with a fly on it, and two others in the neighborhood. The perceptual frame of orientation for the first fly is John's face, whereas the perceptual frame of orientation for John's face is the bed and the perceived vertical that goes with it. Strict application of the principle of canonical orientation leads one to predict that it is appropriate to say "there is a fly to the left of John's nose". The intrinsic (horizontal) dimension relating the fly to John's nose is in canonical position with respect to the perceptual frame of orientation, which is John's face (both for the fly and for the nose).

The second fly is so close to John's head that the face can be the perceptual frame of orientation for this fly as well. Accordingly, the principle of canonical orientation allows one to say "there is a fly above John's head". In this case the perceptual frame of orientation for the located object (the second fly) is John's head. The intrinsic (vertical) dimension relating the fly to John's head is in canonical position with respect to this frame of orientation. But here it should be noticed that the perceptual frame for the referent object (John's head) is the bed, which has a different orientation. It is therefore crucial for the principle of canonical orientation to be stated in terms of the located object's perceptual frame of orientation. For fly 1 and fly 2 the perceptual frame of orientation is John's head. In Figure 7d, however, the balloon's perceptual frame of orientation is not the chair, but the mat on the floor. Therefore, the balloon is not above the chair, whereas fly 2 is above John's head. In other words, the referent object may or may not be the located object's frame of orientation.

Perceptual limitations on talking about space

The determining conditions are probably Gestalt-like, having to do with foreground/background and size relations. They will not be further analyzed here.

The third fly, finally, is at quite a distance from John's head. It does not naturally take John's head as its perceptual frame of orientation, but the scene as a whole, which has a clear vertical orientation. That orientation is not compatible with the intrinsic vertical dimension required to say "there is a fly above John's head". The principle correctly forbids the latter expression for a fly that far away.

It is not difficult to construct similar examples for the dimension "in front of"/"behind", which is the main subject of this section. If John would be facing up to the ceiling, for instance, and there would be a fly just above his nose (deictically), one could felicitously say "there is a fly in front of John's nose". This would predictably break down for a far-away fly.

The principle of canonical orientation has an unexpected but important consequence for the use of "above" and "below", as will be discussed in the next section.

5. DEICTIC AND INTRINSIC USE OF "ABOVE" AND "BELOW"

The last dimension to be considered is the vertical one. It differs in major respects from the previous two dimensions, both for the deictic and for the intrinsic use. Let us turn to deictic use first. The first observation to be made is that for deictic use of "above"/"below" the point of view of the viewer/speaker with respect to the scene is irrelevant. Remember that we defined deictic use as an interpretation of spatial terms from the viewer/speaker's perspective. If the viewer's point of view is irrelevant, what aspect of perspective is at stake, then, for deictic use of "above" and "below"? Well, it is merely the vertical orientation of the speaker's perspective. This state of affairs is depicted in Figure 8.

Let us assume that the viewer who is in position (1)

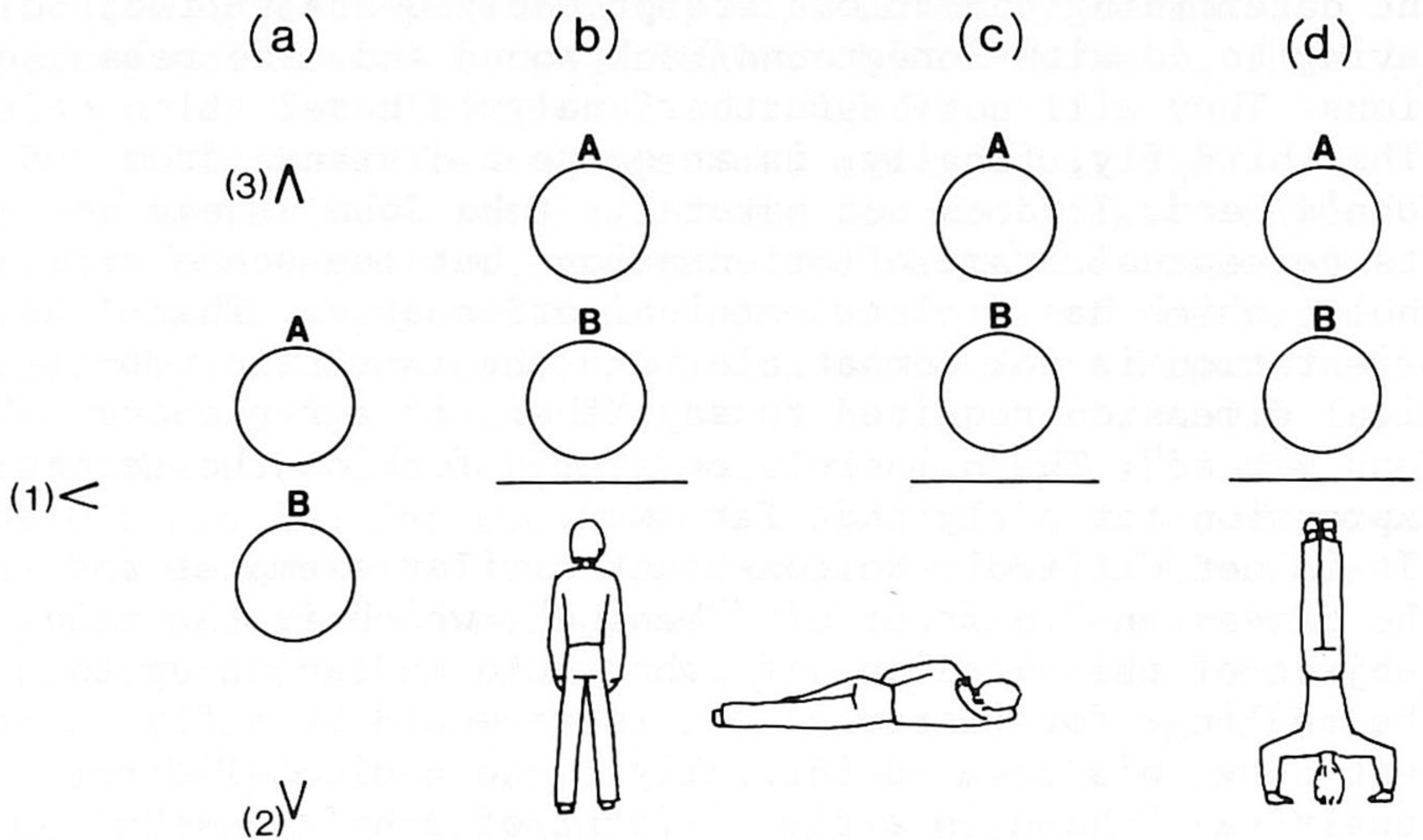

Figure 8. Some uses of "above" and "below".

of Figure 8a perceives balloon A as being above balloon B (and hence B as below A). If the viewer now moves to position (2) and looks up, he can still say that A is above B, and B below A. The same holds when the viewer moves up to position (3) and looks down at the balloons; A is still above B and B below A from that point of view. This shows that the speaker's point of view with respect to the scene is immaterial. The orientation of the viewer/speaker's body is not crucially at stake either. If he or she perceives A as being above B while standing upright as in Figure 8b, nothing will change in this respect when the viewer lies down as in Figure 8c.

What is at stake is perceived verticality, in just the same way as perceived horizontality was at stake in the deictic use of "left" and "right". And the cues involved are analogous. The observer can perceive the scene as vertically arranged on the basis of (1) its being aligned with the retina's vertical meridian, (2) its orientation with respect to some visual frame (horizon or whatever), and (3) its alignment with the vestibular

Perceptual limitations on talking about space

vertical. The first type of cue works in Figure 8b, but not in 8c (same as Figure 3f) or in Figure 3e. The second type of cue is realized in Figures 8b, 8c (=3f), but not in Figures 3d and 3e. The vestibular cue, finally, was meant to be working in Figures 8b, 8c (=3f) and 3e, but not in Figure 3d. None of the cues is indispensable; the impression of verticality can derive from each cue alone. In case of conflicting cues the situation will be very similar to the one discussed in connection with Table 1; an example is given in Figure 8d, where retinal and vestibular alignment are in conflict. Intuitions waver for this case, but we will refrain from further analyses.

The deictic system for "above"/"below" has the usual properties of converseness and of transitivity. That it is fully regular in this respect is not completely trivial given the fact that the viewer/speaker's point of view is irrelevant in this deictic system.

Is there any intrinsic use of "above"/"below"? The literature is unanimously affirmative on this issue. When an object has an intrinsic top, like a person, a car, or a house, something can be above that object. Similarly, if an object has an intrinsic bottom, such as a chair, a plane, or a monkey, something can be "below" it. Still, there is good reason to doubt whether "above"/"below" can be used intrinsically in any way comparable to the intrinsic use of "left"/"right" or "before"/"behind", and we will show that this follows naturally from the principle of canonical orientation discussed above.

The difficulties in using "above"/"below" intrinsically become immediately apparent when one tries to create cases where converseness or transitivity is violated; this appears to be impossible. Figure 9a shows two chairs vertically aligned. Clearly, chair B is below chair A, but it would be highly inappropriate to say that "chair A is below chair B". There is strict converseness here in spite of the similarity to the situation in Figure 5b, where converseness for "in front of"/"behind" was violated. It doesn't help to make the situation more symmetrical, as in Figure 9b.

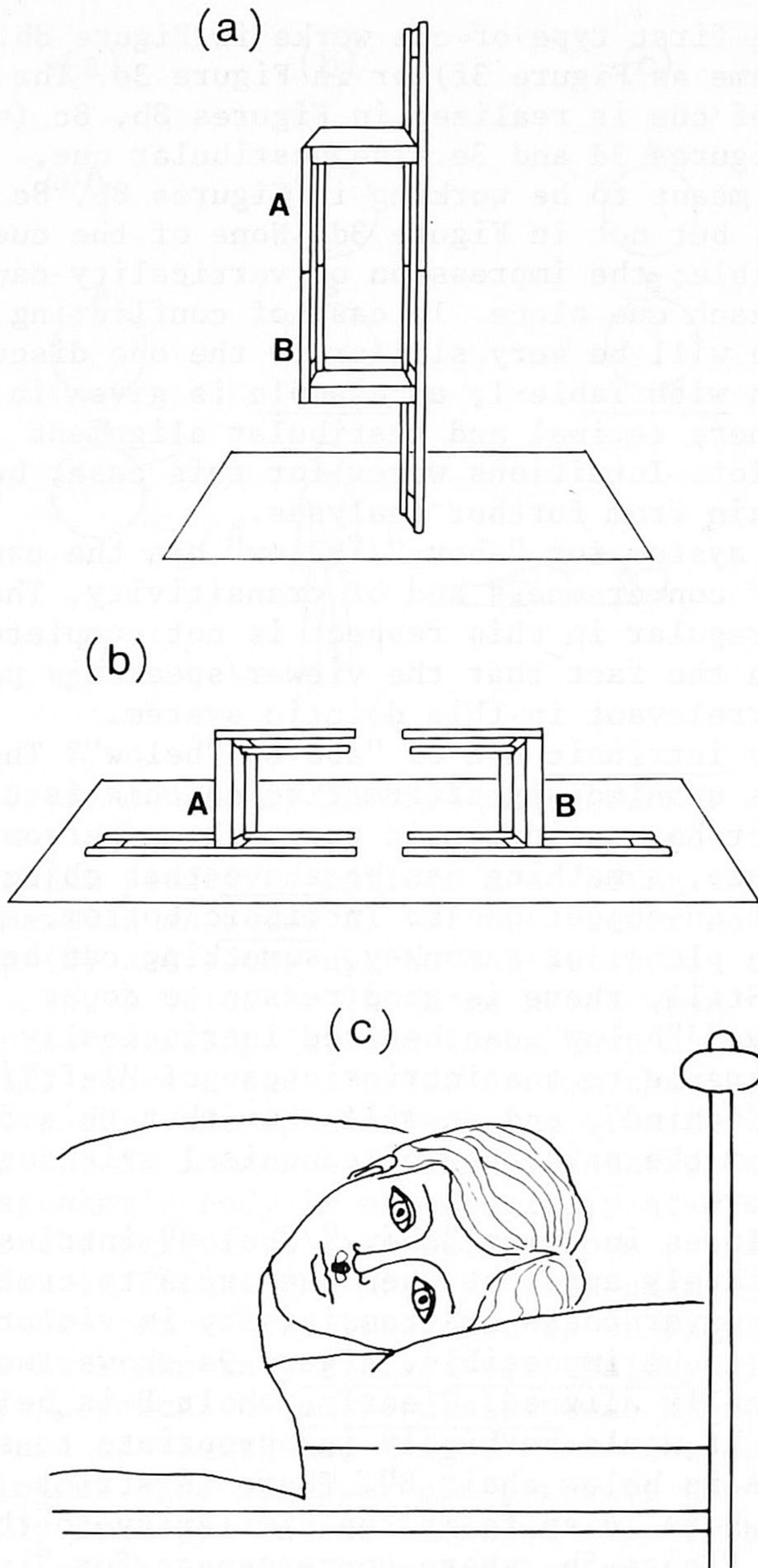

Figure 9. "Above", "below", and the principle of canonical orientation.

Perceptual limitations on talking about space

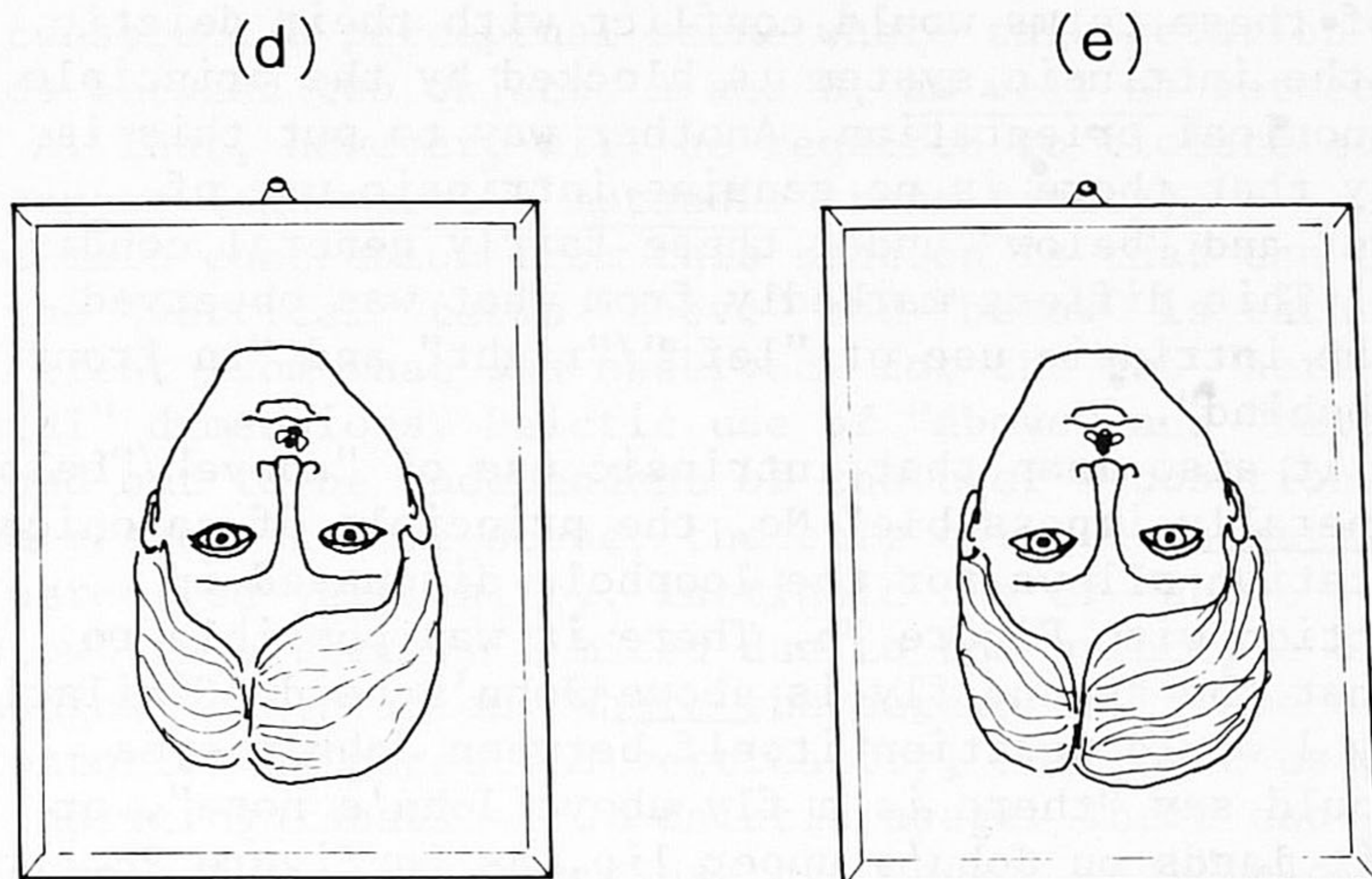

Figure 9. (continued)

There, one can neither say that A is below B, nor that B is below A.

The reason why converseness (and transitivity for that matter) cannot be violated in these or similar cases is that at least one of the two objects does not occupy its normal position with respect to the perceptual frame, i.e. with respect to what is experienced as vertical. In both situations, 9a and 9b, the principle of canonical orientation is violated. In Figure 9a chair A is in canonical position, but chair B isn't, therefore it is impossible to use "below B" intrinsically. In Figure 9b both chairs are in non-canonical position, one can therefore neither say "B is below A", nor "A is below B". Clearly, there is no solution for which both chairs are in canonical position with respect to a common perceptual frame of orientation.

But then, the consequence of the principle is far-reaching for all cases where the perceptual frame of orientation for the two objects is the perceived vertical: intrinsic use of "above"/"below" is possible in just those cases where deictic use predicts the same usage of terms. In other words, as soon as the intrinsic

use of these terms would conflict with their deictic use, the intrinsic system is blocked by the principle of canonical orientation. Another way to put this is to say that there is no genuine intrinsic use of "above" and "below" under these fairly general conditions. This differs markedly from what was observed for the intrinsic use of "left"/"right" and "in front of"/"behind".

Does it also mean that intrinsic use of "above"/"below" is generally impossible? No, the principle of canonical orientation allows for the loophole discussed in connection with Figure 7h. There it was possible to say that the second fly is above John's head. Similarly, if fly 1 would position itself between John's eyes, one could say "there is a fly above John's nose", or when it lands on John's upper lip, as in Figure 9c, it is all right to say "there is a fly below John's nose". In such cases, as we discussed, John's head is the perceptual frame of orientation for the fly; perceived verticality is not at stake, and there is genuine intrinsic usage of "above" and "below".

But even in these cases converseness cannot be violated. This is again due to the principle of canonical orientation. Take the situation of Figure 9c. There the fly is below John's nose, but it is impossible to say "John's nose is below the fly" and the reason is clear: the perceptual frame of orientation for the fly is John's face, and the fly is thus not in canonical position. A seeming counterexample is given in Figure 9d. Let us assume for a change that this is a painting of John's face in upside-down position. One may be able to say here "Pictor painted a fly under the nose", as well as "Pictor painted the nose under the fly". But alas, the latter expression is not intrinsic at all, but deictic; the fly's orientation is immaterial, as is clear from Figure 9e which allows equally well for the same expression.

The principle of canonical orientation requires for the intrinsic use of "above" and "below" that the referent object is (part of) the frame of orientation of the located object. It is hard, if not impossible,

Perceptual limitations on talking about space

to construct a perceptual scene where this relation holds between two objects A and B, as well as between B and A. That, however, will be required to violate converseness (and mutatis mutandis transitivity).

The main conclusion from this section is that the use of the "vertical" terms "above" and "below" is rather different from what was observed for the two "horizontal" dimensions. Deictic use of "above" and "below" turned out to be independent of the user's position with respect to the scene; the only thing that matters is perceived verticality. Intrinsic use of "above" and "below" is extremely limited due to the principle of canonical orientation. Where the perceptual frame of orientation is perceived verticality, intrinsic usage is indistinguishable from deictic usage. There can only be genuine intrinsic use of "above" and "below" for other perceptual frames of orientation. But these latter cases are quite limited as well; it is for instance still impossible to violate converseness or transitivity.

6. CONCLUSIONS AND EPILOGUE

The use of spatial prepositions is obviously related to the ways in which spatial relations are experienced. These experiences are both perception- and memory-based, and often involve extensive knowledge about functional properties of objects. The uses of "left of"/"right of", "in front of"(before)/"behind", and "above"/"below" are almost always related to what is experienced as vertical. The perception of verticality is not only essential for deictic use, i.e. for expressing relations relative to one's own perspective, but also, and unexpectedly, for intrinsic use, i.e. for expressing relations relative to intrinsic dimensions of the referent objects themselves. The way in which a perceptual frame of orientation, in most cases experienced verticality, is involved in intrinsic usage was expressed as the principle of canonical orientation:

the spatial prepositions involved can only be used intrinsically if the referent object is in its canonical orientation with respect to the dimension under concern. What is canonical depends on the perceptual frame of orientation for the located object; it is usually perceived verticality.

The way in which the impression of verticality comes about is an important, but for our purposes secondary issue. The reader is referred to Mittelstaedt (1983) for a thorough analysis. The phenomenological evidence seems to indicate that none of the three major types of cue (retinal orientation, visual frame information and vestibular information) is indispensable, and that the cooperation of two cue types can overrule a cue of the third type. But vestibular information gives the sense of verticality an objective quality which cannot be attained by means of the other two types of cue.

A further finding was that the deictic use of "left"/"right" and of "in front of"/"behind", but not of "above"/"below" depends on the point of view of the observer with respect to the scene. Intrinsic use, we found, is also quite different for "above"/"below" than for the two other dimensions. The principle of canonical orientation severely restricts genuine intrinsic usage of "above" and "below".

A major cause for the difficulties people experience in the use of dimensional terms is no doubt the co-existence of deictic and intrinsic systems of spatial reference. The mathematical properties of the intrinsic system make it, moreover, rather opaque for tasks involving verbal reasoning. Paradoxically, therefore, the most knowledge-based of the two systems is the least accessible to logical deduction.

This brings us, finally, to the questions of the functional significance (if any) of this duplicity, and of how language users prevent potential confusion between the systems. Answers to these important questions can only be very tentative, and require analyses surpassing the purposes of this paper. The following summary considerations merely serve as an epilogue.

Are there any functional reasons for languages to have

Perceptual limitations on talking about space

this duplicity of systems? Not everything in language can be explained in terms of functional adaptation or selection, but if the two systems show marked differences in use, one would at least understand why both systems can coexist within a language community. Empirical evidence for differences in use between the systems is fairly limited.

The most elaborate study is Ehrich's (1984). She asked subjects to describe spatial arrangements of doll furniture in a specially constructed little room. She arranged objects in such a way that deictic and intrinsic perspective could lead to opposite uses of spatial expressions. The major finding was a heavy preponderance of deictic use. Ehrich argued that the deictic system is easier when the task is to describe a complex spatial arrangement. Intrinsic description is only possible if all reference objects have an intrinsic perspective, such as chairs and cupboards. If this is not the case (as with tables and lampshades) it is necessary to alternate between intrinsic and deictic description. An exclusively deictic strategy is more uniform then. It should, moreover, be remembered that the intrinsic system is less useful for tasks requiring verbal reasoning. It will, therefore, be hard for a listener to construct the complex spatial arrangement from an intrinsic description. A deictic strategy may thus have communicative advantage in describing complex spatial arrangements.

These advantages of using the deictic system are plausible, but then one should wonder whether the intrinsic system has similar advantages in other situations. Wunderlich (1981) found that speakers preferred the intrinsic perspective when the task was to describe a relation between just two fixed objects, one of which having a prominent front side, such as a building. One would further expect preference for intrinsic use when the speaker knows that the listener will have difficulties in reconstructing the speaker's point of view with respect to the scene. It is unlikely that evolution has anticipated the development of telephone communication, but indeterminacy of the

speaker's point of view can also arise in other situations; one evolutionary advantage of an acoustic communication system such as a spoken language is precisely that it can be used when the interlocutors are not within one another's sight. And these are just the situations where uncertainty can exist with respect to a speaker's perspective.

A cautionary remark on functional explanations for the use of deictic versus intrinsic strategies should be made, however. We found that people differ strongly in their preferences for intrinsic or deictic use. Where these preferences come from is unclear, but it is not unlikely that they relate to handedness - intrinsic use is somewhat more marked among (latent) left-handers than among right-handers (cf. Levelt 1982b).

The choice of an intrinsic or deictic way of describing spatial relations is, at any rate, multiply determined, and the listener will often not be able to predict the speaker's choice from the non-linguistic context. Do speakers help their listeners to determine which system they are using? Sometimes a speaker marks the deictic usage of "left", "right", "in front of", etc. by adding "from my point of view", or "seen from here". But this is the exception rather than the rule. There are, however, several linguistic means of signalling which system is in use. "A is to the left of B" is rather neutral between the systems, but "A is on the left of B", or "A is on B's left" indicates intrinsic perspective (the latter would, for instance, be more appropriate in the situation of Figure 1b than in the one of Figure 1a). In Dutch, "A is aan de linker-kant van B" ("A is at the left side of B") will, similarly, tend to be interpreted as intrinsic rather than deictic, since it suggests that B has a left side of its own. Hill (1982) argues that for French, "à la gauche de ma soeur" can only be interpreted intrinsically, whereas "à gauche de ma soeur" can be either intrinsic or deictic. And Ehrich (1983) adds the observation that the same distinction holds for the German forms "zu ihrer Linken" (only intrinsic) and "links von ihr" (neutral). The reader is referred to

Perceptual limitations on talking about space

these publications and to Wunderlich (1981) and Levelt (1982b) for a discussion of other linguistic devices used by speakers to indicate which of the systems is in operation.

Clearly, these means are often insufficient for preventing trouble in linguistic communication. But where language fails, perceptual verification may adequately compensate. It is a rare case where the limits of language and perception are simultaneously exceeded.

Acknowledgments. This paper is based on perceptual and linguistic intuitions. They should be distrusted. Melissa Bowerman screened an earlier version for doubtful cases, and constructed some highly convincing counterexamples which forced me to change the theory. Other helpful comments came from Emmon Bach, Herb Clark, and from the members of the Language Production Group in our institute.

REFERENCES

- Clark, H.H. (1973). Space, time, semantics, and the child. In: Cognitive development and the acquisition of behavior, T.E. Moore (ed). New York: Academic Press.
- Corballis, M.C. and Beale, I.L. (1976). The psychology of left and right. Hillsdale: Lawrence Earlbaum.
- Ehrich, V. (1984). Zur Linguistik und Psycholinguistik der sekundären Raumdeixis. In: Sprache und Raum, H. Schweizer (ed). Stuttgart: Metzeler.
- Ehrich, V. and Koster, Ch. (1983). Discourse organization and sentence form: The structure of room description in Dutch. *Discourse Processes*, 6, 91-105.
- Hill, C. (1982). Up/down, front/back, left/right. A contrastive study of Hausa and English. In: Here and there. Cross-linguistic studies on deixis and demonstration, J. Weissenborn and W. Klein (eds). Amsterdam: Benjamins.

- Johnson-Laird, P.N. (1980). Mental models in cognitive science. *Cognitive Science*, 4, 71-115.
- Johnson-Laird, P.N. (1983). *Mental models*. Cambridge: University Press.
- Kaufman, L. (1974). *Sight and mind*. New York: Oxford University Press.
- Klein, W. (1982). Lexical deixis in route directions. In: *Speech, place, and action*, R.J. Jarvella and W. Klein (eds). Chichester: Wiley.
- Levelt, W.J.M. (1981). The speaker's linearization problem. *Phil. Trans. R. Soc. Lond. B* 295, 305-315.
- Levelt, W.J.M. (1982a). Linearization in describing spatial networks. In: *Processes, beliefs, and questions*, S. Peters and E. Saarinen (eds). Dordrecht: Reidel.
- Levelt, W.J.M. (1982b). Cognitive styles in the use of spatial direction terms. In: *Speech, place, and action*, R.J. Jarvella and W. Klein (eds). Chichester: Wiley.
- Linde, Ch. and Labov, W. (1975). Spatial networks as a site for the study of language and thought. *Language*, 51, 924-939.
- Miller, G.A. and Johnson-Laird, P.N. (1976). *Language and perception*. Cambridge, Mass.: Harvard University Press.
- Mittelstaedt, H. (1983). A new solution to the problem of the subjective vertical. *Naturwissenschaften*, 70, 272-281.
- Weissenborn, J. and Klein, W. (eds). (1982). *Here and there. Cross-linguistic studies on deixis and demonstration*. Amsterdam: Benjamin.
- Wunderlich, D. (1981). Linguistic strategies. In: *A Festschrift for native speaker*, F. Coulmas (ed). The Hague: Mouton.